

FSB

SoftBend™ Fiber Series - Fiber Assemblies (G.657A)

The Fiber Reinforced Plastic (FRP) cable-based SoftBend™ single mode optical fiber series is ITU-T G.657A compliant and fully compatible with other standard single mode fibers complying with ITU-T G.652, thus ensuring excellent splicing performance and compatibility with legacy networks. The SoftBend™ fiber's bend-insensitivity is beneficial for use in Fiber-to-the-Home (FTTH), enterprise networks or other applications where a small bend radius may be encountered. It maintains low bending loss across the full usable spectrum of wavelengths between 1260nm and 1625nm. SoftBend™ fiber assemblies can improve reliability of some critical services such as triple-play by significantly reducing the bending loss compared to conventional single mode fibers, and offer better service reliability, which can increase subscriber's satisfaction and retention, and revenue opportunities. As a result of reduced bend radius, it enables tighter routing and higher fiber density for device design in CO/CPE equipment and backplane solutions.



Applications

- Installation with as small as 15mm cable bending radius for indoor cable mounting.
- Face plate in the house and the Cabinet at the SDF.
- Drop/Distribution cable installation for Fiber-to-the-home (FTTH), triple-play service and Local Area Networks installation.
- Device design for tighter routing and higher fiber density.

Key Features

- Optical and bending loss performance fully compliant to ITU G.657A single mode fiber.
- Fully compatible with ITU G.652 standard ensuring seamless splicing to existing G.652 fiber.
- Its metallic armoured cables have excellent mechanical properties to avoid any damage caused by rodent animals.
- Offering Metallic Armoured and Non-Metallic cables, and patch cords and Pigtail with ST, SC, FC, LC type and others connectors.
- RoHS compliance.

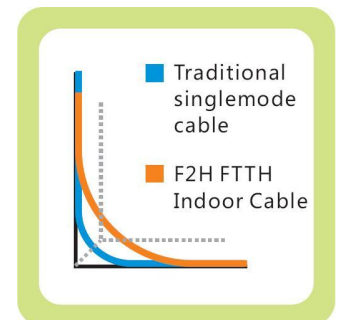
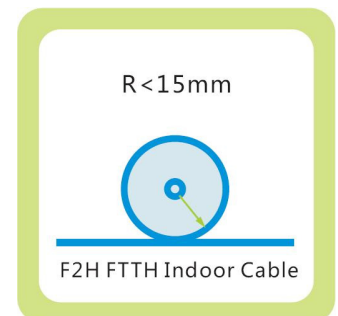
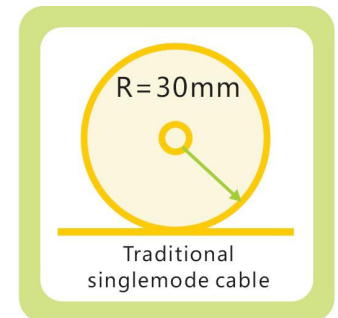

FibreOptica A series – Metallic Armoured indoor cable

A series fiber cable is designed for FTTH indoor horizontal & vertical, high density installation. Metallic armoured cables have excellent mechanical properties which can prevent any damage caused by rodent animals.

Cable Structure	
Tight buffer Fiber	Φ600um/Φ900um micro-bend fiber
Kevlar	Dubang 1580 x 2
Metallic soft tube	Φ1.2 ±0.1 mm*Φ1.7 ±0.1 mm
stainless steel yarn	stainless steel 304-0.07H
PE outer sheath	Φ3.0 ±0.2 mm/Φ3.3 ±0.2 mm

Cable Characteristics	
Max attenuation Coefficient	1310nm ≤ 0.3 0 dB/km
	1550nm: ≤ 0.2 0 dB/km
Working temperature	-20 to +75°C

Mechanical Characteristics	
Tensile strength(N)	≥ 200
Crush test(N/100mm)	≥ 2000
Min bending radius (mm)	15mm
Impactive test(mm2Kg)	150H±5
Weight	24Kg/Km

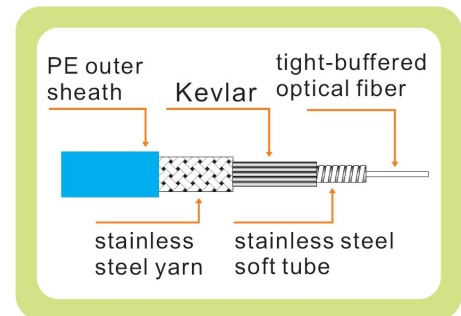

Ordering Information

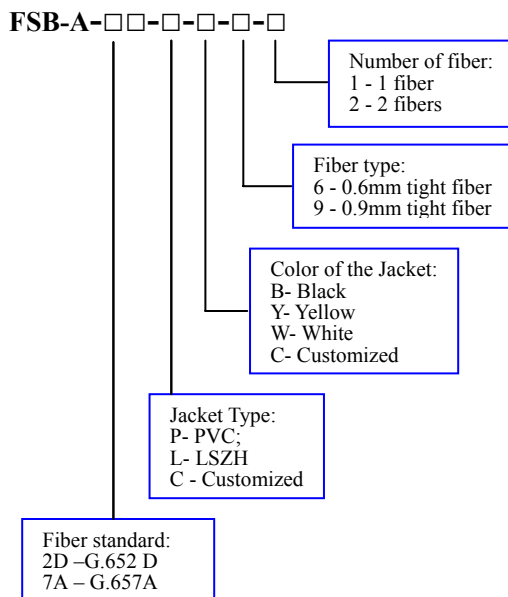

FibreOptica E Series Cable – Figure "8" cable

FibreOptica E series fiber cable is designed for FTTH installation, Indoor cables, Drop/Distribution cables. It can be used with mechanical splicers. The fiber is in the center of the cable and two strengthening mandrills are on the two sides of the fiber. The fiber and strengthening mandrills are coated together into a fiber cable - "8" Shape design.

- Simple structure, anti press, anti pull, anti aging.
- "8" Shape design, enabling easy strip of the jacket, easy installation and maintenance.
- An additional micron permanent protective coating on the glass cladding makes it the most robust fiber in the telecommunications industries.
- Small-bending fatigue lifetime is several hundred times longer than other standard single mode fibers.

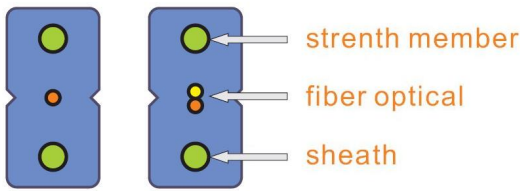

Model	FSB-E
Fiber diameter(um)	250
Fiber Type	G.657A
Attenuation Coefficient	1310nm: ≤0.35dB/km 1550nm: ≤0.22dB/km 1383nm ≤0.31dB/km 1625nm: ≤0.23dB/km
Mode Field Diameter @ 1310 nm	8.6±0.4
Mode Field Diameter @ 1550 nm	9.5±0.4
Core/clad concentricity error	<2%
Min bending radius mm	15

Attenuation with Bending	
Φ30mm,10 turns, at 1550nm macro bend add attenuation	≤0.25dB
Φ30mm,10 turns, at 1625nm macro bend add attenuation	≤1.0dB
Φ20mm,1 turns, at 1550nm macro bend add attenuation	≤0.75dB
Φ20mm,1 turns, at 1625nm macro bend add attenuation	≤1.5dB
Cut-off wavelength λ _{cc}	1260 nm
zero dispersion wavelength	1300 to 1324 nm
Fiber number	1/2/4
Cable Weight(kg/km)	<10
Tensile strength(N) long/short term	30/60
Crush test(N/100mm) long /short term	1000/2000

Ordering Information

FSB-E-□□-□□-□□-□□-□□

Fiber standard:
2D - G.652 D
7A - G.657A

Jacket Type:
P- PVC;
L- LSZH
C - Customized

Number of fiber:
1 - 1 Fiber
2 - 2 Fibers

Fiber type:
2-250um Fiber
T-Tight

Strengthening mandrill type:
F-FRP (Fiber-glass reinforced Plastics)
S-Steel

Color of the Jacket:
B- Black
Y- Yellow
W- White
C- Customized

SoftBend Fiber Accessories

FibreOptica's SoftBend Fiber patchcord and pigtails are new accessories designed for the need of the next-generation FTTH and FTTD. SoftBend Fiber Assemblies include three series: FSB-I, FSB-II and FSB-III.

FSB-I: metallic armoured indoor patchcord series

FSB-II: Non-metal patchcord series

FSB-III: pigtail series

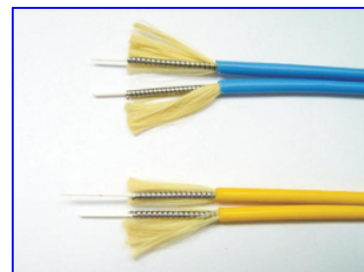
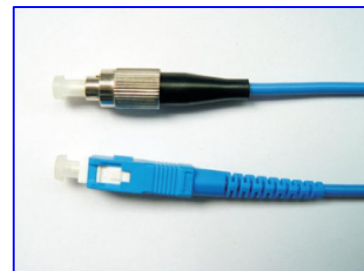

Specifications			
Item	PC	UPC	APC
Material	Ceramic		
Insert Loss (dB)	< 0.2	< 0.2	< 0.2
Return Loss (dB)	≥ 45	≥ 50	≥ 60
Fiber Type	G.657A		
Repeatability (500times) (dB)	Δ 0.2		
Tensile Strength (N)	70 (Armored 200, SC)		
Working Temperature	-20 to +80°C		
Storage Temperature	-20 to +80°C		
Working Humidity	< 90% RH		

Ordering Information

